

# OCHIAI

## Riding type tea plucking machine **MODEL TFC-8**



More advanced fuel efficiency

	Model	TFC-8
measurements	Length (mm)	2900(operational) 1605(storage)
	Width (mm)	2163
	Height (mm)	1900
	AGL (mm)	987 ( at frame center)
	Crawler length (mm)	1631(at gauge1850)
	Weight (kg)	1000
	Crawler(widthxlength)	180 x 1605
	Crawler material	Rubber
	Model	FH680D-AS01
engine	type	Air cooling, 2 cylinder, 4cycle, gasoline powered
	Displacement (cc)	680
	Rated power/ rev	14.5kW(19.7PS)/3600rpm
	Fuel capacity (ℓ)	20
	Work efficiency	10a or above / 1 hour (depends on farm condition)

Smaller than previous model

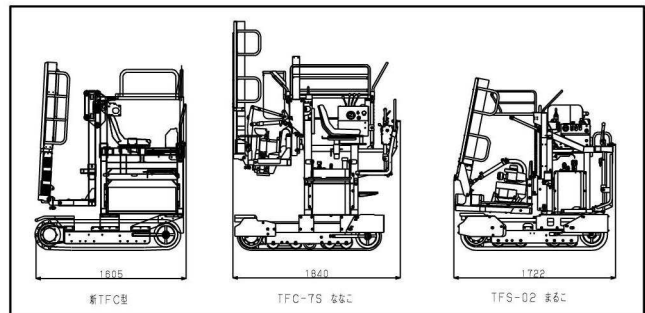

7Sななこより約**230mm**      まるこ より**100mm**以上短い  
**運転スペースは広々**

Revolving driver seat

